

Database documentation: rdb

K. A. Mackay

NIWA Internal Report
2001

Revised on 20 January 2001

Contents

1	Introduction to the Database Document series	3
2	Research Database	3
3	Data Structures	3
3.1	Table relationships	3
3.2	Database Standards	7
3.3	Official Code Tables	7
3.4	MAF Fisheries Project Management	8
4	Table Summaries	9
5	rdb Tables	10
5.1	Table 1: area_codes	10
5.2	Table 2: t_door_dist_codes	10
5.3	Table 3: t_fish_meas_codes	11
5.4	Table 4: t_fish_obs_codes	11
5.5	Table 5: t_fix_meth_codes	11
5.6	Table 6: force_chk	12
5.7	Table 7: t_headline_codes	12
5.8	Table 8: t_gon_sys_desc	13
5.9	Table 9: t_gon_stg_meth	13
5.10	Table 10: lw_coeff	14
5.11	Table 11: meth_codes	15
5.12	Table 12: t_nation	15
5.13	Table 13: species_desc	16
5.14	Table 14: species_usage	16
5.15	Table 15: species_master	17
5.15.1	curr_spp	18
5.16	Table 16: t_samp_sel_codes	19
5.17	Table 17: t_sex_codes	19
5.18	Table 18: t_stom_cond_codes	19
5.19	Table 19: t_stom_state_codes	20
5.20	Table 20: t_wgt_meth_codes	20
5.21	Table 21: t_wing_dist_codes	20
5.22	Table 22: vessels	21
5.23	Table 23: t_proj_header	22
5.24	Table 24: t_proj_contract	23
6	rdb business rules	24
6.1	Introduction to business rules	24
6.2	Summary of rules	25
	Appendix 1 – Reference code tables	32

List of Figures

Figure 1:	Entity Relationship Diagram (ERD) for the species codes tables	4
Figure 2:	ERD of the gonad staging methodology tables	6
Figure 3:	ERD for the historical MAF Fisheries Project Management System	8

1 Introduction to the Database Document series

The National Institute of Water and Atmospheric Research (NIWA) currently carries out the role of Data Manager and Custodian for the fisheries research data owned by the Ministry of Fisheries (MFish).

The Ministry of Fisheries data set incorporates historic research data, data collected more recently by MAF Fisheries prior to the split in 1995 of policy to the Ministry of Fisheries and research to NIWA, and currently data collected by NIWA and other agencies for the Ministry of Fisheries.

This document is a brief introduction to the research database **rdb**, and is part of the database documentation series produced by NIWA. It supersedes the previous documentation by Mackay (1997)¹ on this database.

All documents in this series include an introduction to the database design, a description of the main data structures accompanied by an Entity Relationship Diagram (ERD), a listing of all the main tables, and information system business rules. The ERD graphically shows how all the tables link together and their relationship with other databases.

This document is intended as a guide for users and administrators of the **rdb** database.

Access to this database is restricted to specific nominated personnel as specified in the current Schedule 6 of the Data Management contract between the Ministry of Fisheries and NIWA. Any requests for data should in the first instance be directed to the Ministry of Fisheries.

2 Research Database

The **rdb** database is the central database for the Ministry of Fisheries contract work in NIWA, containing 23 key reference code tables and views that are referenced by all other research databases.

Also contained within the **rdb** database are tables from a legacy 4GL application. This application managed all research project contract between the MAF Fisheries Research and MAF Fisheries Policy groups. This application became redundant with the merger of MAF Fisheries Research and NIWA in 1996. These tables, although now inactive, are retained for historical interests.

3 Data Structures

3.1 Table relationships

This database contains a collection of entities that range from single unrelated tables to tables with slightly more complicated relationship structures. Figures 1-3 show the ERDs for these related

¹ MACKAY, K.A., 1996: Marine Research database documentation: 15 rdb. *NIWA Internal Report (Fisheries) No. 252*. 34p.

tables, which illustrate their logical structure² and entities (each entity is implemented as a database *table*). This schema is valid regardless of the database system chosen, and it can remain correct even if the Database Management System (DBMS) is changed. Each table represents an object, event, or concept in the real world that is selected to be represented in the database. Each *attribute* of a table is a defining property or quality of the table. All of the table's attributes are shown in the ERD. The underlined attributes represent the table's primary key³.

Physical Data Model		
Project : rdb database		
Model : Species codes		
Author : dba	Version 1	1/3/01

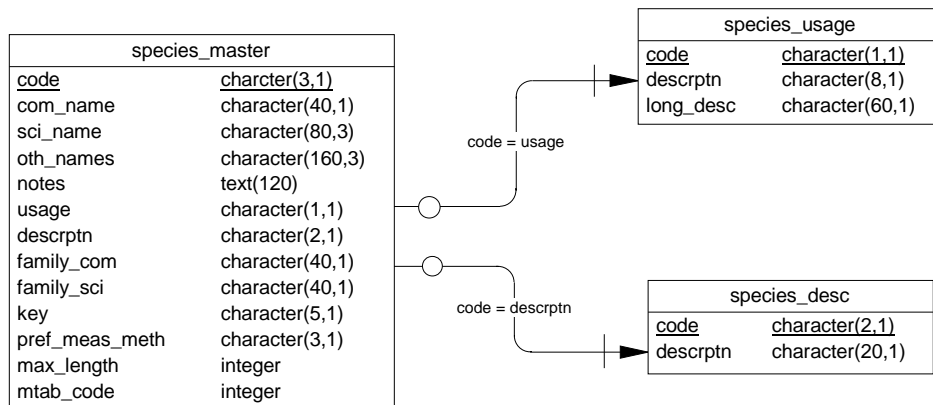

curr_spp	
species_master.code	charcter(3,1)
species_master.com_name	character(40,1)
species_master.sci_name	character(80,3)
species_master.oth_names	character(160,3)
species_master.notes	text(120)
species_master.usage	character(1,1)
species_master.descrptn	character(2,1)
species_master.family_com	character(40,1)
species_master.family_sci	character(40,1)
species_master.key	character(5,1)
species_master.pref_meas_meth	character(3,1)
species_master.max_length	integer
species_master.mtab_code	integer
<input type="checkbox"/> species_master	

Figure 1: Entity Relationship Diagram (ERD) for the species codes tables

² Also known as a database *schema*.

³ A primary key is an attribute or a combination of attributes that contains an unique value to identify that record.

The **rdb** database is implemented as a relational database; i.e., each table is a special case of the mathematical construct known as a *relation* and hence elementary relation theory is used to deal with the data within tables and the relationships between them. There are three types of relationships possible between tables, but only one exists in **rdb**: one-to-many⁴. These relationships can be seen in ERDs by connecting a single line (indicating ‘many’) from the child table; e.g., *t_gon_stg_meth*, to the parent table; e.g., *t_gon_sys_desc*, with an arrowhead (indicating ‘one’) pointing to the parent. Note that the word ‘many’ applies to the possible number of records in one table that one record in another table is associated with. For a given instance, there might be zero, one, two, or more associated records, but if it is ever possible to have more than one, we use the word ‘many’ to describe the association.

Every relationship has a mandatory or optional aspect to it. If a relationship is mandatory, then it has to occur at least once, while an optional relationship might not occur at all. For example, in Figure 2, consider that relationship between the table *t_gon_sys_desc* and its child table *t_gon_stg_meth*. The symbol “O” by the child *t_gon_stg_meth* means that a gonad staging system record can have zero or many matching gonad stage method code records, while the bar by the parent *t_gon_sys_desc* means that for every gonad stage method code record there must be a matching gonad staging system record.

These links are enforced by referential constraints⁵. Constraints do not allow *orphans* to exist in any table; i.e., where a child record exists without a related parent record. This may happen when: a parent record is deleted; the parent record is altered so the relationship is lost; or a child record is entered without a parent record

Constraints are shown in the table listings by the following format:

```
Referential:      constraint name (attribute[, attribute]) |INSERT|
                                                           |DELETE|
                  parent table (attribute[, attribute])
```

Note that the typographical convention for the above format is that square brackets [] may contain more than one item or none at all. Items stacked between vertical lines || are options of which one must be chosen.

For example, consider the following constraint found in the table *t_landing*:

```
Referential:      invalid stage meth code (stage_meth) INSERT
                  t_gon_sys_desc (stage_meth)
```

This means that the value of the attribute *stage_meth* in the current record must already exist in the parent table *t_gon_sys_desc* or the record will be rejected and the following message will be displayed:

```
*** User Error: insert constraint 'invalid stage meth code' violation
```

⁴ A one-to-many relationship is where one record (the *parent*) in a table relates to one or many records (the *child*) in another table; e.g., one gonad staging system in *t_gon_sys_desc* can have many gonad stage method codes in *t_gon_stg_meth* but one gonad stage method code can only come from one gonad staging system.

⁵ Also known as integrity checks.

Section 5 lists all the **rdb** tables as implemented by the Empress DBMS. As can be seen in the listing of the tables, a table's primary key has a unique index on it. Primary keys are generally listed using the following format:

Indices: UNIQUE index_name ON (attribute[, attribute])

where attribute(s) make up the primary key and the index name is the primary key name. These prevent records with duplicate keys from being inserted into the tables; e.g., a species record being inserted with an existing species code.

The database listing (Tables 1-24) show that the tables also have indices on many attributes. That is, attributes that are most likely to be used as a searching key have like values linked together to speed up searches. These indices are listed using the following format:

Indices: NORMAL (2, 15) index_name ON (attribute[, attribute])

Note that indices may be simple, pointing to one attribute or composite pointing to more than one attribute. The numbers "...(2, 15)..." in the syntax are Empress DBMS default values relating to the amount of space allocated for the index.

Physical Data Model		
Project : rdb database		
Model : Gonad staging method codes		
Author : dba	Version 1	1/3/01

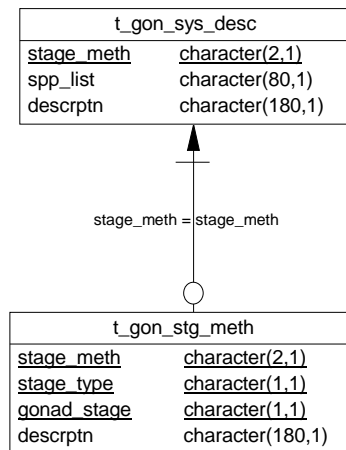

Figure 2: ERD of the gonad staging methodology tables

3.2 Database Standards

Many of the tables in the **rdb** database were created before the introduction of the Marine Research Computing database standards⁶. Therefore, these tables do not comply with all the standards, most notably the addition of the prefix “t_” to the table names to distinguish them from attribute names. A decision was made to retain these original names as most of the tables in the **rdb** database are accessed or referenced by software applications throughout the organization, including data checking and data loading routines, stock assessment and biomass calculations, plus the myriad of personal scripts written by users. Any change could therefore have a significant flow-on effect throughout NIWA. All tables created after the introduction of the database standards do comply, and are easily recognized by the “t_” prefix to their name.

3.3 Official Code Tables

There are currently 23 official code tables residing in the **rdb** database. The majority of which are single tables, such as *area_codes* (Table 1) and *t_dist_door_codes* (Table 2), which contain a code and its definition. There are some more complicated structures involving between two and four tables which will be explained later in this document.

The most fundamental of all research codes are the species codes. Not only are they used by nearly every other fisheries research database in NIWA, they also are the legal codes used for all Ministry of Fisheries data activities, such as CELRs. Therefore, the codes are dependant not only on the species, but also the intended usage. All species codes are held in the *species_master* table (Table 15, Figure 1). This table also stores the common, scientific, family names as well as other commonly used names, e.g., orange roughy, *Hoplostethus atlanticus*, also known as deepsea perch. Species codes usage is controlled by the code *usage*, which is the primary key to the table *species_usage* (Table 14). To aid in searches, the species codes have been broadly categorized into groups such as shellfish, birds, etc by the code *descrptn*. This code is defined in the *species_desc* table (Table 13).

To prevent obsolete species codes from being used in other databases the view *curr_spp*, literally - current species codes, was created. This view is based on the SQL SELECT statement that selects all attributes from *species_master* where the code *usage* does not equal “O” (for obsolete).

Length/weight coefficients for important species are stored in another table *lw_coeff* (Table 10), which is connected to *species_master* by a referential constraint. There can be more than one record per species in this table, usually depending on the age, time of year, and area the raw dataset was collected. The default set of coefficients is flagged by the attribute *ts_default* to be used in the biomass and checkq⁷ programs.

Gonad stage method codes (Figure 2) is also more than just a single table because such codes depend not only the species, sex, and sexual maturity, but more importantly on who is collecting the data and what results they are trying to get out. Two tables are used. The first, *t_gon_sys_desc* (Table 8), defines the gonad staging method code *stage_meth* by who uses the code and on what species. The second table *t_gon_stg_meth* (Table 9) describes that state of the gonad for each staging method, species, sex, and gonad stage code.

⁶ Ng, S. 1992: Standards for setting up databases and their applications. *MAF Fisheries Greta Point Internal Report No. 180*. 31p

⁷ checkq is a language written by MAF Fisheries staff to validate raw ASCII files against a format file of business rules prior to insertion into a RDBMS.

3.4 MAF Fisheries Project Management

While no longer in use since the merger with of MAF Fisheries Research with NIWA, this group of tables and its associated application is still important in the historical context.

The former MAF Fisheries Project Management system kept track of a number of defined projects through the table *t_proj_header* (Table 23, Figure 3) as they progressed from the proposal stage through to approval. If the project reached approval status a contract was created between MAF Fisheries and MAF Policy for the current financial year. The details of this project are held on the *t_proj_contract* table (Table 24). If the project spanned several years then a new contract was created for every subsequent financial year. This resulted in one project having many contracts, as shown by the one-to-many relationship in the ERD.

Of course, not all projects reached approval status, many being rejected after proposal. This is reflected in the ERD by the optional symbol “O” on the one-to-many relationship between *t_proj_header* and *t_proj_contract*.

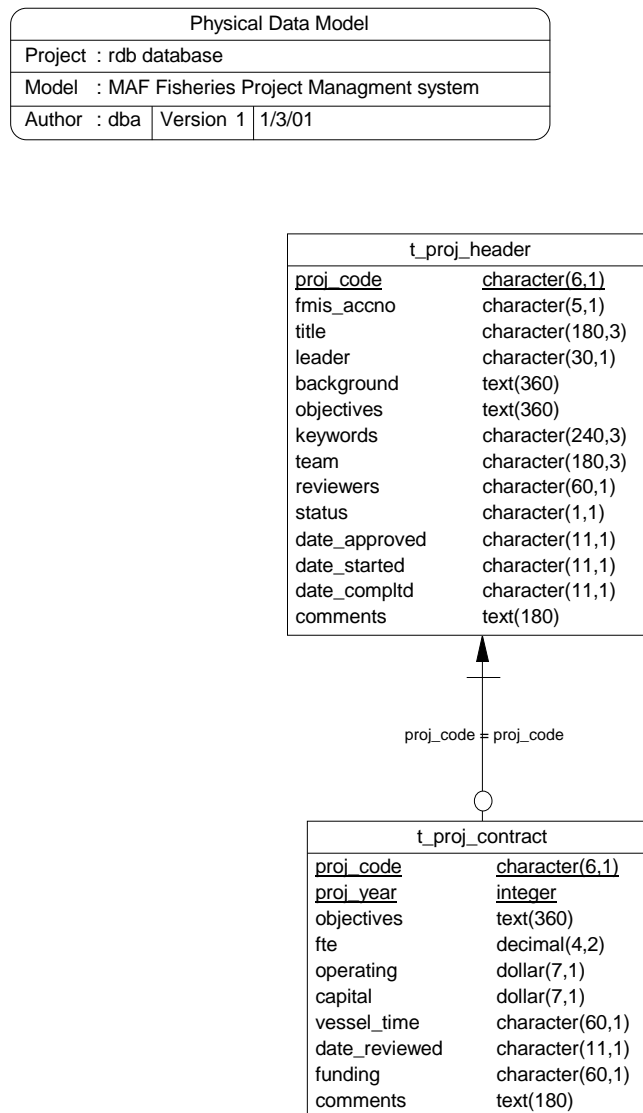

Figure 3: ERD for the historical MAF Fisheries Project Management System

4 Table Summaries

The following is a listing of the tables contained in the **rdb** database:

- **Official code tables**

1. **area_codes** : contains a list of codes denoting the various survey areas in New Zealand waters.
 2. **t_door_dist_codes** : contains a complete list of codes describing how the distance between the doors was derived.
 3. **t_fish_meas_codes** : contains a list of current preferred methods of length measurement used.
 4. **t_fish_obs_codes** : contains a list of codes showing placement of fish at the net mouth during the shot as seen on the net sonde.
 5. **t_fix_meth_codes** : contains a complete list of method codes for fixing a position.
 6. **force_chk** : is used for cross-checking beaufort scale, wind speed, and sea condition.
 7. **t_headline_codes** : contains a list of codes to describe how the headline height was derived.
 8. **t_gon_sys_desc** : stores a description of each gonad staging system used.
 9. **t_gon_stg_meth** : stores descriptions of each gonad stage comprising each gonad staging system.
 10. **lw_coeff** : contains coefficients used to calculate the weight of a fish from its length.
 11. **meth_codes** : contains a list of 2-digit codes of data collection methods used for fisheries research.
 12. **t_nation** : contains ISO standard country names and codes.
 13. **species_desc** : contains all species description codes, e.g., fish, crustacea, molluscs.
 14. **species_usage** : lists codes for the usage of species codes, e.g., species code used by ITQ management or research etc.
 15. **species_master** : contains a list of species codes, scientific and common names and other details for use in ALL Research and Operations databases.
 - a) **curr_spp** : is a view on *species_master* of all current species codes.
 16. **t_samp_sel_codes** : contains a list of 1-digit codes for the method by which fish have been selected for length frequency sampling.
 17. **t_sex_codes** : contains a list of codes for the sex of fish.
 18. **t_stom_cond_codes** : contains a list of codes for the condition of digested prey in stomachs.
 19. **t_stom_state_codes** : contains a list of codes for the state of stomach fullness.
 20. **t_wgt_meth_codes** : contains a list of codes for the method which the sample weight was derived.
 21. **t_wing_dist_codes** : contains a list of codes describing how the distance between the wings was derived.
 22. **vessels** : contains a list of 3-character codes and names of vessels used in to collect Fisheries Research data.
- **MAF Fisheries Project Management (inactive since 1996)**
 - 24 **t_proj_header** : contains header information for Marine Research projects.
 - 25 **t_proj_contract** : contains information on yearly contracts drawn up for each project with MAF Policy.

5 rdb Tables

The following are listings of the tables in the **rdb** database, including attribute names, data types (and any range restrictions), and comments.

Official Code Tables

5.1 Table 1: area_codes

Comment: Complete list of 3- or 4-letter codes denoting the various survey areas, QMAs, river catchments, and statistical areas in and around New Zealand and the EEZ.

Attributes	Data Type	Null?	Comment
code	character(4,1)	No	3- or 4-character code for each unique area.
descrptn	character(60,1)	No	Description of area code.

Creator: dba
Indices: UNIQUE area_pk ON (code)

5.2 Table 2: t_door_dist_codes

Comment: Complete list of codes describing how the distance between the trawl doors (door spread) was derived.

Attributes	Data Type	Null?	Comment
door_code	character(1,1)	No	1-character code for how door spread was derived.
descrptn	character(60,1)	No	Description of door spread code.

Creator: dba
Indices: UNIQUE door_pk ON (door_code)

5.3 Table 3: t_fish_meas_codes

Comment: List of current preferred methods of length measurement used, lengths are rounded down to nearest cm class (mm for scampi).

Attributes	Data Type	Null?	Comment
fish_meas_code	character(1,1)	No	1-character code for measurement method.
descrptn	character(65,1)	No	Description of measurement method code.

Creator: dba

Indices: UNIQUE fishmeas_pk ON (fish_meas_code)

5.4 Table 4: t_fish_obs_codes

Comment: Complete list of codes showing placement of fish at the net mouth during the shot as seen on the net sonde.

Attributes	Data Type	Null?	Comment
fish_obs_code	character(1,1)	No	1-character code for fish observation on net sonde.
descrptn	character(60,1)	No	Description of fish observation code.

Creator: dba

Indices: UNIQUE fishobs_pk ON (fish_obs_code)

5.5 Table 5: t_fix_meth_codes

Comment: Complete list of codes for the methods used for fixing a position of an observation.

Attributes	Data Type	Null?	Comment
fix_meth_code	character(2,1)	No	2-character code for method of fixing a position.
descrptn	character(60,1)	No	Description of position fix code.

Creator: dba

Indices: UNIQUE fix_pk ON (fix_meth_code)

5.6 Table 6: force_chk

Comment: This table is used for crosschecking beaufort scale, wind speed, and sea condition.

Attributes	Data Type	Null?	Comment
force	smallint range 0 to 12	No	Beaufort scale.
min_spd	smallint range 0 to 30		Minimum valid wind speed (m/s) for beaufort scale.
max_spd	smallint range 1 to 127		Maximum valid wind speed (m/s) for beaufort scale.
min_seac	smallint range 0 to 8		Minimum valid sea condition code for beaufort scale.
max_seac	smallint range 1 to 9		Maximum valid sea condition code for beaufort scale.
Creator:	dba		
Indices:	UNIQUE force_chk_pk ON (force)		

5.7 Table 7: t_headline_codes

Comment: Complete list of codes to describe how the trawl headline height was derived.

Attributes	Data Type	Null?	Comment
headline_code	character(1,1)	No	1-character code for method of measuring headline height.
descrptn	character(60,1)	No	Description of headline height measurement method code.
Creator:	dba		
Indices:	UNIQUE head_pk ON (headline_code)		

5.8 Table 8: t_gon_sys_desc

Comment: This table stores the codes and descriptions of each gonad staging system used.

Attributes	Data Type	Null?	Comment
stage_meth	character(2,1)	No	2-character code to uniquely identify the different gonad staging systems.
spp_list	character(80,1)		List of species (separated by commas) for which this method is valid.
descrptn	character(180,1)	No	Description of staging system, including references
Creator:	dba		
Indices:	UNIQUE gonsys_pk	ON	(stage_meth)

5.9 Table 9: t_gon_stg_meth

Comment: Table to store the codes and description for each gonad stage comprising each staging system.

Attributes	Data Type	Null?	Comment
stage_meth	character(2,1)	No	2-character code to uniquely identify gonad staging system used. Refer t_gon_sys_desc
stage_type	character(1,1)		1-character code to say what is being staged: 1 = males; 2 = females; E = eggs.
	smatch "[12E]"		
gonad_stage	character(1,1)	No	1-character code for actual stage under the system.
descrptn	character(180,1)	No	Description of the actual gonad stage.
Creator:	dba		
Referential:	invalid stage_meth code	(stage_meth)	INSERT t_gon_sys_desc (stage_meth)
Indices:	UNIQUE gonstg_pk	ON	(stage_meth, stage_type, gonad_stage)
	NORMAL (2, 15)	ON	gonstg_stage_type_ndx (stage_type)
	NORMAL (2, 15)	ON	gonstg_stage_meth_ndx (stage_meth)

5.10 Table 10: lw_coeff

Comment: Coefficients used to calculate weight of fish from length, where weight is calculated from the equation:

$$weight = a * length^b * length^{(c * \ln(length))}$$

Weight in grams and length in centimetres. The *a*, *b*, and *c* coefficients may vary within a species.

Attributes	Data Type	Null?	Comment
spp_code	character(3,1)	No	3-character species code to which the length/weight coefficients apply.
sex	integer		Numeric code for sex to which the length/weight coefficients apply (1=males,2=females).
ts_default	character(1,1) range: = "Y"		'Y' = default length/weight coefficients for trawl survey analyses, otherwise null.
lw_coeff_a	decimal(7,6)		Coefficient a.
lw_coeff_b	decimal(7,6)		Coefficient b.
lw_coeff_c	decimal(7,6)		Coefficient c.
meas_meth	character(3,1)		Measurement method(s) used to establish the fish length. Refer t_fish_meas_codes.
reference	character(80,1)		Publication references etc.
Creator:	dba		
Indices:	NORMAL (2, 15) lw_spp_indx ON (spp_code)		

5.11 Table 11: meth_codes

Comment: Complete list of 2-digit codes of data collection methods used in Fisheries Research.

Attributes	Data Type	Null?	Comment
code	character(2,1) range: match "[0-9]"	No	2-digit code for each unique data collection method
meth_code	character(3,1)		3-character Ministry of Fisheries code.
task_code	character(4,1)		4-character code for the generic task
descrptn	character(60,1)	No	Description of method code.
Creator:	dba		
Indices:	UNIQUE meth_pk ON (code)		

5.12 Table 12: t_nation

Comment: ISO standard country names and codes.

Attributes	Data Type	Null?	Comment
country	character(40,1)		Country name.
ISO_2_char	character(2,1)		Country ISO standard 2-letter code.
ISO_3_char	character(3,1)		Country ISO standard 3-letter code.
ISO_num	integer		Country ISO standard 3-digit code.
Creator:	dba		
Indices:	UNIQUE nation_pk ON (ISO_num)		

5.13 Table 13: species_desc

Comment: Complete listing of all species description codes and their meaning.

Attributes	Data Type	Null?	Comment
code	character(2,1) smatch "[A-Z][A-Z-]"	No	1st character for main group; e.g. Fish, Shellfish, Reptiles, etc.; 2nd character for sub-group; e.g. Billfish, Lightfish, etc.
descrptn	character(20,1)	No	Description of the species usage code.
Creator:	dba		
Indices:	UNIQUE desc_pk ON (code)		

5.14 Table 14: species_usage

Comment: Complete listing of all species code usages and their meaning.

Attributes	Data Type	Null?	Comment
code	character(1,1) smatch "[A-Z]"	No	1-character code for the usage of a species code.
descrptn	character(8,1)		Short 8-character description used in query screen displays.
long_desc	character(60,1)		Long 60-character description used in reports.
Creator:	dba		
Indices:	UNIQUE usage_pk ON (code)		

5.15 Table 15: species_master

Comment: Complete list of species codes and details for use in ALL Research and Operations databases.

Attributes	Data Type	Null?	Comment
code	character(3,1) smatch "{[A-Z]}"	No	3-character (uppercase) unique code for the species.
com_name	character(40,1)		Preferred common name for the species.
sci_name	character(80,3)		Scientific name for the species.
oth_names	character(160,3)		Other names associated with the species.
notes	text(40,120,40,1)		Any notes about features, peculiarities etc. of the species.
usage	character(1,1)		Describes whether code is for ITQ, Research etc. Usage 0=Obsolete code (refer species_usage).
descriptn	character(2,1)		Brief description of species - fish, shellfish, etc.
family_com	character(40,1)		Common family name.
family_sci	character(40,1)		Scientific family name.
key	character(5,1)		Identification key. First character represents the type of fish: B=Bony fish; C= Cartilaginous fish (sharks and rays). Numbers refer to the genera identification key in Paulin C, Stewart A, Roberts C, McMillan P. 1989. New Zealand Fish. A complete Guide. 279p. ISBN 0-477-01427-5
pref_meas_meth	character(3,1)		Up to 3 preferred measurement methods, see t_fish_meas_codes.
max_length	integer range 0 to 9999		Maximum length recorded (to be used only as a guide)
mtab_code	integer range 0 to 999		3-digit code to identify species for use in the Minitab statistical software or any other software that can only work with numbers and not characters.

species_master (cont...)

Creator: dba
Referential: invalid usage (usage) INSERT species_usage (code)
invalid desc (descrptn) INSERT species_desc (code)
invalid pref_meas_meth (pref_meas_meth) INSERT
t_fish_meas_codes (fish_meas_code)
Indices: UNIQUE spp_pk ON (code)
NORMAL (2, 15) sp_com_ndx ON (com_name)
NORMAL (2, 15) sp_sci_ndx ON (sci_name)
NORMAL (2, 15) sp_oth_ndx ON (oth_names)
NORMAL (2, 15) sp_use_ndx ON (usage)
NORMAL (2, 15) sp_des_ndx ON (descrptn)

The following listing is a view of the table *species_master* listing only the current species codes.

5.15.1 curr_spp

Comment: View on the table species_master of all current species codes. May be used for species codes validation in other tables and databases.

View: select attr 'code', attr 'com_name', attr 'sci_name', attr 'oth_names', attr 'notes', attr 'usage', attr 'descrptn', attr 'family_com', attr 'family_sci', attr 'key', attr 'pref_meas_meth', attr 'max_length', attr 'mtab_code' from 'species_master' where (attr 'usage' != '0')

Attributes	Data Type	Null?	Comment
code	character(3,1)	No	
com_name	character(40,1)		
sci_name	character(80,3)		
oth_names	character(160,3)		
notes	text(40,120,40,1)		
usage	character(1,1)		
descrptn	character(2,1)		
family_com	character(40,1)		
family_sci	character(40,1)		
key	character(5,1)		
pref_meas_meth	character(3,1)		
max_length	integer		
mtab_code	integer		

Creator: dba

5.16 Table 16: t_samp_sel_codes

Comment: Complete list of 1-digit codes for the method by which fish have been selected for length frequency sampling.

Attributes	Data Type	Null?	Comment
samp_sel_code	character(1,1)	No	1-character code for method of sample selection.
descrptn	character(60,1)	No	Description of sample selection code.

Creator: dba

Indices: UNIQUE sel_pk ON (samp_sel_code)

5.17 Table 17: t_sex_codes

Comment: Complete list of codes for the sex of a fish. May also be used to distinguish gonad and egg stages for some female fish.

Attributes	Data Type	Null?	Comment
sex_code	character(1,1)	No	1-character code for sex of fish.
descrptn	character(60,1)	No	Description of sex code.

Creator: dba

Indices: UNIQUE sex_pk ON (sex_code)

5.18 Table 18: t_stom_cond_codes

Comment: Complete list of codes for the condition of digested prey in stomachs.

Attributes	Data Type	Null?	Comment
stom_cond_code	character(1,1)	No	1-character code for prey digestion condition.
descrptn	character(60,1)	No	Description of digestion condition code.

Creator: dba

Indices: UNIQUE stm_cnd_pk ON (stom_cond_code)

5.19 Table 19: t_stom_state_codes

Comment: Complete list of codes for state of fullness of stomach.

Attributes	Data Type	Null?	Comment
stom_state_code	character(1,1)	No	1-character code for state of stomach fullness.
descrptn	character(60,1)	No	Description of stomach state code.
Creator:	dba		
Indices:	UNIQUE stm_state_pk ON (stom_state_code)		

5.20 Table 20: t_wgt_meth_codes

Comment: Complete list of codes for the method by which the sample weight was derived.

Attributes	Data Type	Null?	Comment
wgt_meth_code	character(1,1)	No	1-character code for method of weighing sample/catch.
descrptn	character(60,1)	No	Description of weighing method code.
Creator:	dba		
Indices:	UNIQUE wgt_pk ON (wgt_meth_code)		

5.21 Table 21: t_wing_dist_codes

Comment: Complete list of codes describing how the distance between the trawl wings was derived.

Attributes	Data Type	Null?	Comment
wing_dist_code	character(1,1)	No	1-character code for method of deriving trawl wing spread.
descrptn	character(60,1)	No	Description of trawl wing spread code.
Creator:	dba		
Indices:	UNIQUE wing_pk ON (wing_dist_code)		

5.22 Table 22: vessels

Comment: List of vessel names & codes used in Fisheries Research data.

Attributes	Data Type	Null?	Comment
code	character(3,1) smatch "[a-z0-9]"	No	3-character lowercase vessel name code.
name	character(20,1)	No	Vessel name.
Creator:	dba		
Indices:	UNIQUE ves_pk ON (code)		

MAF Fisheries Project Management Tables

5.23 Table 23: t_proj_header

Comment: Header information for Marine Research projects.

Attributes	Data Type	Null?	Comment
proj_code	character(6,1)	No	Unique project code, used as project identifier in other tables.
fmis_accno	character(5,1)		FMIS/Financel account number associated with the project, assigned for approved projects.
title	character(180,3)		Title of the project.
leader	character(30,1)		Project leader's name.
background	text(60,360,30,1)		Background information about the project.
objectives	text(60,360,30,1)		Detailed summary of the overall objectives of the project.
keywords	character(240,3)		Important keywords associated with the project.
team	character(180,3)		Staff involved in the project. Leader's name first
reviewers	character(60,1)		Names of people asked to review the project.
status	character(1,1) smatch "[PANDC]"		Status of the project - Proposed, Approved, Not Approved, Discontinued, or Completed.
date_approved	character(11,1)		Date (Mmm yyyy) the project was approved by Manager, Marine Research, Greta Point.
date_started	character(11,1)		Starting date (Mmm yyyy) of the project.
date_compltd	character(11,1)		Completion date (Mmm yyyy) of the project.
comments	text(60,180,60,1)		Any other comments related to the project.
Creator:	dba		
Indices:	UNIQUE ON (proj_code) NORMAL (2, 15) ON (fmis_accno) NORMAL (2, 15) ON (status)		

5.24 Table 24: t_proj_contract

Comment: Information on yearly contracts drawn up for each project with MAF Policy.

Attributes	Data Type	Null?	Comment
proj_code	character(6,1)	No	Unique project code, used as a project identifier.
proj_year	integer	No	Year for which the project contract was drawn up (financial year beginning 1st July).
objectives	text(60,360,30,1)		Detail summary of the objectives of the year project contract.
fte	decimal(4,2)		Full Time Equivalent index. A measure of how many full time staff are needed for the contract period.
operating	dollar(7,1)		Operating budget for the contract period.
capital	dollar(7,1)		Capital budget for the contract period.
vessel_time	character(60,1)		Amount of vessel time needed for the contract period.
date_reviewed	character(11,1)		Date (dd Mmm yyyy) of review of the contract.
funding	character(60, 1)		Source of funding (if other than MAF Policy).
comments	text(60,180,60,1)		Any other comments related to the contract.
Creator:	dba		
Referential:	invalid project code (proj_code) INSERT t_proj_header (proj_code)		
Indices:	UNIQUE ON (proj_code, proj_year)		

6 rdb business rules

6.1 Introduction to business rules

The following are a list of business rules applying to the **rdb** database. A business rule is a written statement specifying what the information system (i.e., any system that is designed to handle market sampling data) must do or how it must be structured.

There are three recognised types of business rules:

Fact	Certainty or an existence in the information system.
Formula	Calculation employed in the information system.
Validation	Constraint on a value in the information system.

Fact rules are shown on the ERD by the cardinality (e.g., one-to-many) of table relationships. Formula and Validation rules are implemented by referential constraints, range checks, and algorithms both in the database and during validation.

Validation rules may be part of the preloading checks on the data as opposed to constraints or checks imposed by the database. These rules sometimes state that a value should be within a certain range. All such rules containing the word 'should' are conducted by preloading software. The use of the word 'should' in relation to these validation checks means that a warning message is generated when a value falls outside this range and the data are then checked further in relation to this value.

6.2 Summary of rules

Area codes table (area_codes)

code	Area code, must have a value entered that is an unique alphanumeric code of not more than 4 characters.
descrptn	Must have a value entered than can be any combination of ASCII characters.

Trawl door distance codes table (t_door_dist_codes)

door_code	Must have a value entered that is an unique 1-character alphanumeric code.
descrptn	Must have a value entered than can be any combination of ASCII characters.

Fish measurement method codes table (t_fish_meas_codes)

fish_meas_code	Must have a value entered that is an unique 1-character alphanumeric code.
descrptn	Must have a value entered than can be any combination of ASCII characters.

Fish observation codes table (t_fish_obs_codes)

fish_obs_code	Must have a value entered that is an unique 1-character alphanumeric code.
descrptn	Must have a value entered than can be any combination of ASCII characters.

Position fix method codes table (t_fix_meth_codes)

fix_meth_code	Must have a value entered that is an unique alphanumeric code of not more than 2 characters.
descrptn	Must have a value entered than can be any combination of ASCII characters.

Beaufort scale, wind speed, and sea condition table (force_chk)

force	Must have an integer entered that is a valid Beaufort Scale number that is within the range of 0 to 12.
min_spd	Must be an integer and should be within the reasonable range of 0 to 30.
max_spd	Must be an integer and should be within the reasonable range of 1 to 127.
min_seac	Must be an integer as listed in Appendix 1 and should be within the reasonable range of 0 to 8.
max_seac	Must be an integer as listed in Appendix 1 and should be within the reasonable range of 1 to 9.

Trawl headline height measurement method codes table (t_headline_codes)

headline_code	Must have a value entered that is an unique 1-character alphanumeric code.
descrptn	Must have a value entered than can be any combination of ASCII characters.

Gonad staging system table (t_gon_sys_desc)

stage_meth	Must have a value entered that is an unique alphanumeric code of not more than 2 characters.
spp_list	Each species code in the list must be a valid code as listed in the <i>curr_spp</i> table.
descrptn	Must have a value entered than can be any combination of ASCII characters.

Gonad staging method codes table (t_gon_stg_meth)

stage_meth	Must have a value entered that is an alphanumeric code of not more than 2 characters.
stage_type	Must have a value entered and be a valid stage type code as listed in Appendix 1.
gonad_stage	Must have a value entered that is a 1-character alphanumeric code Multiple column check on <i>stage_meth</i>, <i>stage_type</i>, and <i>gonad_stage</i>: The combination of the attributes <i>stage_meth</i> , <i>stage_type</i> , and <i>gonad_stage</i> must be unique.
descrptn	Must have a value entered than can be any combination of ASCII characters.

Length/weight coefficients table (lw_coeff)

spp_code	Must have a value entered that is a valid species code as listed in the <i>curr_spp</i> table.
sex	Must be an integer that is either equal to “1” or “2”.
ts_default	Must be either equal to “Y” or null.
lw_coeff_a	Should be a real number within the reasonable range of 0.0001 to 0.7.
lw_coeff_b	Should be a real number within the reasonable range of 0.5 to 3.8.
lw_coeff_c	Should be a real number within the reasonable range of 0.2 to 0.4.
meas_meth	Must be a valid fish measurement method code as listed in the <i>t_fish_meas_codes</i> table.

Data collection gear method codes table (meth_codes)

code	Must have a value entered that is an alphanumeric code of not more than 2 characters.
meth_code	Must be a valid Ministry of Fisheries method code as listed in Appendix 1.
task_code	Must be a valid task code as listed in Appendix 1.
descrptn	Must have a value entered than can be any combination of ASCII characters.

Data collection gear method codes table (meth_codes)

country	Must be a valid country name as recognised by the International Standards Organisation.
ISO_2_char	Must be a 2-character uppercase alphabetic code.
ISO_3_char	Must be a 3-character uppercase alphabetic code.
ISO_num	Must be an integer between 4 and 900.

Species description codes table (species_desc)

code	Must have a value entered that is an uppercase alphabetic code of not more than 2 characters. Where: the first character must be within the range of A-Z; the second character can be either between the range of A-Z or a hyphen character “-“.
descrptn	Must have a value entered than can be any combination of ASCII characters.

Species usage codes table (species_usage)

code	Must have a value entered that is an unique 1-character uppercase alphabetic code.
descrptn	Can have any combination of up to 8 ASCII characters.
long_desc	Can have any combination of up to 60 ASCII characters.

Master species codes table (*species_master*)

code	Must have a value entered that is an unique 3-character uppercase alphabetic code.
com_name	Can have any combination of up to 40 ASCII characters.
sci_name	Can have any combination of up to 80 ASCII characters.
oth_names	Can have any combination of up to 160 ASCII characters.
usage	Must have a valid species usage code as listed in the <i>species_usage</i> table.
descrptn	Must have a valid species description code as listed in the <i>species_desc</i> table.
family_com	Can have any combination of up to 40 ASCII characters.
family_sci	Can have any combination of up to 40 ASCII characters.
key	The first character must be equal to either a “B” or a “C”. The second to fifth characters must be a number that matches a genera identification key as found in Paulin C, Stewart A, Roberts C, McMillan P. 1989. <i>New Zealand Fish. A complete Guide</i> . 279p. ISBN 0-477-01427-5. Valid ranges are listed in Appendix 1.
pref_meas_meth	Each character of this field must be a valid fish measurement method code as listed in the <i>t_fish_meas_codes</i> table.
max_length	Must be a integer between the range of 0-9999.
mtab_code	Must be a unique integer between the range of 0-999.

Current species codes view (*curr_spp*)

The current species codes view must contain all records in the *species_master* table where the *usage* field is not equal to “O”, i.e., an obsolete code.

Sample selection method codes table (t_samp_sel_codes)

samp_sel_code Must have a value entered that is an unique 1-character alphanumeric code.
descrptn Must have a value entered than can be any combination of ASCII characters.

Sex codes table (t_sex_codes)

sex_code Must have a value entered that is an unique 1-character alphanumeric code.
descrptn Must have a value entered than can be any combination of ASCII characters.

Stomach contents condition codes table (t_stom_cond_codes)

stom_cond_code Must have a value entered that is an unique 1-character alphanumeric code.
descrptn Must have a value entered than can be any combination of ASCII characters.

Stomach state of fullness codes table (t_stom_state_codes)

stom_state_code Must have a value entered that is an unique 1-character alphanumeric code.
descrptn Must have a value entered than can be any combination of ASCII characters.

Weighing method codes table (t_wgt_meth_codes)

wgt_meth_code Must have a value entered that is an unique 1-character alphanumeric code.
descrptn Must have a value entered than can be any combination of ASCII characters.

Trawl wing distance codes table (t_wing_dist_codes)

- wing_dist_code** Must have a value entered that is an unique 1-character alphanumeric code.
- descrptn** Must have a value entered than can be any combination of ASCII characters.

Vessel codes table (vessels)

- code** Must have a value entered that is an unique 3-character alphanumeric code.
- name** Must have a value entered than can be any combination of ASCII characters.

Appendix 1 – Reference code tables

Beaufort scale (force)

<u>Force</u>	<u>Description</u>	<u>Mean Wind Speed (knots)</u>
0	Calm	< 1
1	Light air	1 – 3
2	Light breeze	4 – 6
3	Gentle breeze	7 – 10
4	Moderate breeze	11 – 16
5	Fresh breeze	17 – 21
6	Strong breeze	22 – 27
7	Near gale	28 – 33
8	Gale	34 – 40
9	Strong gale	41 – 47
10	Storm	48 – 55
11	Violent storm	56 – 63
12	Hurricane	> 64

Sea condition codes (min_seac & max_seac)

<u>Code</u>	<u>Description</u>	<u>Wave Height (metres)</u>
0	Calm, glassy	0
1	Calm	0 – 0.1
2	Smooth	0.1 - 0.5
3	Slight	0.5 – 1.0
4	Moderate	1.0 – 2.5
5	Rough	2.5 – 6.0
6	Very Rough	4.0 – 6.0
7	High	6.0 – 10.0
8	Very High	10.0 – 15.0
9	Huge	Over 15.0

Stage type code (stage_type)

<u>Stage type</u>	<u>Description</u>
1	Male
2	Female
E	Eggs

Ministry of Fisheries method codes (meth_code)

<u>Method code</u>	<u>Description</u>
BES	Beach seine
BLL	Bottom longline
BOT	Bottom trawl
BPT	Bottom pair trawl
DAL	Dahn/drop line
DAS	Danish seine
DIV	Diver
HAL	Handline
MWT	Midwater trawl
PAL	Pole line
POT	Pots (generic)
PUS	Purse seine
RLP	Rock lobster pot
SCT	Scampi trawl
SEN	Set (gill) net
SQJ	Squid jig
SLL	Surface longline
TRL	Trot line
TRO	Trolling line
UNK	Unknown

Data collection method task codes (task_code)

<u>Task code</u>	<u>Description</u>
ACOU	Acoustics
BATH	Bathymetry/oceanography
CTDS	CTD probes
DIVE	Diving
DRGE	Dredge
FLOU	Flourimeters
GRAB	Grab
LINE	Line
NETS	Nets
PHOT	Photography
POTS	Pots
SEIN	Seine
TRAP	Traps
TRWL	Trawl

Species identification keys (key)

<u>Fish type</u>	<u>Key range</u>
Cartilaginous fish (sharks and rays)	C1 – C30
Bony fish	B1 – B178